

ARF PLUS PRO HAWK

1/3.75 Scale Almost-Ready-To-Fly RC Jet
Assembly and operations manual



Specifications Hawk 100

Type : T.A.V.S ARF PRO
Length : 131": (3330mm)
Weight : 55 Lbs (25 Kg)
Radio : 12 Channel (10—14 servo's)

Scale : 1/3.75
Span : 107": (2700mm) no missiles
Engine : 42 Lbs (20 Kg) trust

The Bae Hawk T1 and Hawk 100 by Skymaster

Thank you very much for purchasing our Skymaster ARF PRO XXL Hawk . Please note that the photos in this instruction manual show certain views from the prototypes. The instruction manual is same for T1 and 100 models. Some modifications and upgrades might have taken place by the release of the model. We have tried to produce a very scale replica of this classic jet. This manual describes the assembling of " PRO" model. Speed brake, Landing gear and doors are factory installed. Before you start building and setting-up your aircraft, please make sure you have read this instruction manual, and understood it. If you have any questions, please don't hesitate to contact us. Below are the contact details:

Office Taiwan:

No.9.39 Lane, Yuag-Chang 2nd Street, Ren-Wu Hsiang, Kaohsiung Hsien, 814, Taiwan, R.O.C.

TEL: +886 9 3299 7923

FAX: + 886 7373 1215

<http://www.skymasterjet.com>

Sales : skymasterjets@263.net

Technical support : morne.m@pixie.co.za

Skymaster
ARF PLUS

Hawk arf pro

Assembly & Operation Manual

Index:

INTRODUCTION.....	3
DISCLAIMER.....	3
WARNING.....	3
ARF PAINT.....	4
FINISHING YOUR WHITE VIPER ARF.....	4
HANDLING & TRANSPORTING	5
TOOL LIST.....	6
HEALTH.....	7
GENERAL ASSEMBLY TECHNIQUES.....	7
RADIO EQUIPMENT & ACCESSORIES.....	8
KIT CONTENTS.....	9
HARDWARE.....	10
OPTIONAL PARTS.....	11
CONTROL LINKAGES	12
WINGS.....	12
STABILIZERS.....	15
FIN & RUDDER.....	16
FUSELAGE.....	18
TAILPIPE.....	19
FUEL CELLS.....	19
FUEL DIAGRAM.....	20
AIR SYSTEM	21
AIR DIAGRAM.....	22
TURBINE INSTALLATION.....	23
COCKPIT & CANOPY.....	24
EQUIPMENT INSTALLATION INTO THE HAWK ARF.....	25
BEFORE YOU FLY.....	26



Hawk arf pro

Assembly & Operation Manual

INTRODUCTION

Thank you for purchasing Skymaster arf pro Hawk! We have put a lot of effort and time into this model. We at Skymaster strive to be a market leader in the ARF—jet market. We were the first company to produce ARF—jets in the world and we would like to continue being amongst the best. Although we have made every effort that this model was fit for shipping, we would like you to inspect the contents and call your nearest dealer immediately if any defects or missing parts are spotted! This manual will allow you to duplicate the factory prototypes.

LIABILITY

You have acquired a kit, which can be assembled into a fully working R/C model when fitted out with suitable accessories, as described in the instruction manual with the kit. However, as manufacturers, we at Skymaster are not in a position to influence the way you build and operate your model, and we have no control over the methods you use to install, operate and maintain the radio control system components. For this reason we are obliged to deny all liability for loss, damage or costs which are incurred due to the incompetent or incorrect application and operation of our products, or which are connected with such operation in any way. Unless otherwise prescribed by binding law, the obligation of the Skymaster company to pay compensation is excluded, regardless of the legal argument employed. This applies to personal injury, death, damage to buildings, loss of turnover and business, interruption of business or other direct and indirect consequent damages. In all circumstances our total liability is limited to the amount which you actually paid for this model.

BY OPERATING THIS MODEL YOU ASSUME FULL RESPONSIBILITY FOR YOUR ACTIONS.

It is important to understand that Skymaster, is unable to monitor whether you follow the instructions contained in this instruction manual regarding the construction, operation and maintenance of the aircraft, nor whether you install and use the radio control system correctly. For this reason we at Skymaster are unable to guarantee, or provide, a contractual agreement with any individual or company that the model you have made will function correctly and safely. You, as operator of the model, must rely upon your own expertise and judgment in acquiring and operating this model.

WARNING

This 'jet' aircraft is a high-end product and can create an enormous risk for both pilot and spectators, if not handled with care, and used according to the instructions. Make sure that you operate your Hawk according to the AMA rules, or those laws and regulations governing model flying in the country of use. The engine, landing gear, servos, linkages and control surfaces have to be attached properly. Please use only the recommended servos and accessories. Make sure that the 'Centre of Gravity' is located in the recommended place. Use the nose heavy end of the CG range for your first flights. A tail heavy plane can be an enormous danger for you and all spectators. Fix any weights, and heavy items like batteries, very securely into the plane. Make sure that the plane is secured properly when you start the engine. Have a helper hold your plane from the nose before you start the engine. Make sure that all spectators are far behind, or far in front, of the aircraft when running up the engine. Make sure that you range check your R/C system thoroughly before the 1st flight. It is absolutely necessary to range check your complete R/C installation first WITHOUT the engine running. Leave the transmitter antenna retracted, and check the distance you can walk before 'fail-safe' occurs. Then start the engine, run at about half throttle and repeat this range check. Make sure that there is no range reduction before 'fail-safe' occurs. If the range with engine running is less than with the engine off, please DON'T FLY at that time. Make sure that your wing spar tube is not damaged. Check that the anti-rotation dowels for the wings are not loose. Check that the wing, stab, fin and nose retaining bolts are tight. Please don't ignore our warnings, or those provided by other manufacturers. They refer to things and processes which, if ignored, could result in permanent damage or fatal injury. Secure the plane before starting engine.



Hawk arf pro

Assembly & Operation Manual

ARF Paint

The color finish on your Skymaster Hawk arf pro model was applied out of the mould. We have used only the highest standard automotive paints to finish your model.

Should you damage the finish, Skymaster stock the color paint and hardener required for the repair. A good automotive spray painter should also be able to mix and supply the correct samples for repair.

If you have no experience in the use of these paints, it will be best to seek assistance.

Do not leave your model unprotected in the sun! always cover your model or park it in the shade. Extreme temperatures will damage the paint!

Finishing Your All White HAWK ARF PRO

It is always best to fully assemble the model before painting. By doing so no damage or glue prints will ruin the paint.

The all white model will have some release agent on the surfaces.

Use #1000 wet and dry paper to sand the entire model. Mould lines can be sanded and filled using normal automotive fillers.

Please be extra careful when sanding near the hinge line! The hinges can easily be damaged. When masking and painting please make sure the control surfaces are not bend past 90—180 degrees extensively. This will cause the hinges to crack and may cause flutter.

The clear canopy are not installed. It is best to install these components after painting was done.



Hawk arf pro

Assembly & Operation Manual

HANDLING & TRANSPORTING

Composite models are very light but strong. These characteristics do have a down side! It is brittle.

Take care when handling your model. **DO NOT ATTEMPT TO PICK UP AN FULLY FUELED MODEL BY THE LEADING EDGE BY YOURSELF!** The leading edges will crack and delaminate. Full size jets have specially marked access points for the hooks of cranes!

Inspect your model before and after a rough landing. Make sure all parts are safe and sound.

Inspect model before and after transport. A sudden stop can easily cause an unnoticed dent!

The wings and tails are very flight worthy structures. They are light and extremely strong , however, they will dent if mishandled. Always support these structures on clean soft foam rubber.



Hawk arf pro

Assembly & Operation Manual

Tools and Adhesives

Tools etc:

This is a fairly quick and easy plane to build, for a jet model, not requiring difficult techniques or special equipment, but even the building of Skymaster aircraft requires some suitable tools! You will probably have all these tools in your workshop anyway, but if not, they are available in all good hobby shops, or hardware stores like "Home Depot" or similar.

1. Sharp knife (X-Acto or similar)
2. Allen key set (**metric**) 2.5mm, 3mm & 5mm
3. Sharp scissors, curved type for canopy
4. Pliers (various types)
5. Wrenches (**metric**)
6. Slotted and Phillips screwdrivers (various sizes)
7. Drills of various sizes
8. Battery drill and Dremel tool (or similar) with cutting discs, sanding tools and mills
9. Sandpaper (various grits), and/or Permagrit sanding tools (high quality - recommended)
10. Carpet, bubble wrap or soft cloth to cover your work bench (most important !)
11. Car wax polish (clear)
12. Paper masking tape
13. Denaturised alcohol, Acetone, or similar (for cleaning joints before gluing)

Adhesives:

Not all types of glues are suited to working with composite parts.

Here is a selection of what we normally use, and what we can truly recommend. Please don't use inferior quality glues - you will end up with an inferior quality plane, that is not so strong or safe. Jet models require good gluing techniques, due to the higher flying speeds, and hence higher loads on many of the joints. We highly recommend that you use a slow cured epoxy for gluing highly stressed joints, like the hinges and control horns, into position and the most commonly used is 'Aeropoxy' (Bob Violett Models, USA). The self-mixing nozzles make it easy to apply exactly the required amount, in exactly the right place, and it will not run or flow onto places where you don't want it! It takes about 1 - 2 hours to start to harden so it also gives plenty of time for accurate assembly. Finally it gives a superb bond on all fibreglass and wood surfaces. Of course there are many similar glues available, and you can use your favorite type.



1. CA glue 'Thin' and 'Thick' types. We recommend ZAP, as this is a very high quality.
2. ZAP-O or Plasti-ZAP, odourless (for gluing the clear canopy)
3. 30 minute epoxy (stressed joints must be glued with 30 min and NOT 5 min epoxy).
4. Aeropoxy/Loctite Hysol 3462 or equivalent (optional, but highly recommended)
5. Epoxy laminating resin (12 - 24 hr cure) with hardener.
6. Milled glass fibre, for adding to slow epoxy for stronger joints.
7. Micro-balloons, for adding to epoxy for lightweight filling.
8. Thread-locking compound (Loctite, or equivalent)

At Skymaster we try our best to offer you a high quality kit, with outstanding value-for money, and as complete as possible. However, if you feel that some additional or different hardware should be included, please feel free to let us know.



Hawk arf pro

Assembly & Operation Manual

HEALTH

Use a mask (available at auto paint stores) to protect from inhaling the glass or carbon fiber dust. Use this mask whenever you are sanding or cutting fiberglass or carbon fiber materials. Use a charcoal filter paint mask (available at auto paint supply stores) when spraying any primer or paint. Spray out of doors or in a properly vented spray booth. Use safety glasses any time rotary tools, such as Dremel cut-off disc or Perma-Grit cutters, are being used.

GENERAL ASSEMBLY TECHNIQUES

We recommend to wax the model before assembling. This will help protect the finish from an epoxy finger print. Wax will not help for CA glues!

Extra glue, extra paint, extra resin will add up to a heavy model. Plan before you glue! The glass cloth side of parts to glue, should be sanded with #80 grit paper for best glue adhesion.

Support the fuselage on foam pads.

Skymaster makes every attempt to insure that the parts fit. However, due to manufacturing tolerances, some parts may fit a little tight. Always trial fit parts and adjust if needed.

Only use high quality adhesives such as the ZAP products from Pacer Technology.

For extremely high stress areas we recommend "Aeropoxy." It is the strongest and best gripping adhesive we have found.

If fuel or grease are on the surface, first clean with acetone or thinners.

Clean off all excess glue—excess glue is excess weight.

Always check the outside skin of the model to look for any glue residue and remove it with Acetone before it cures. "Aeropoxy" is tough to remove once it has thoroughly cured.



Hawk arf pro

Assembly & Operation Manual

Radio equipment

Failure to use the recommended servos, output arms, extensions, and hardware may result in a loss of control!

Throughout this manual we make use of various types of servos and radio equipment! We have used JR equipment during the installation process. If you make use of another manufacturer, please use equipment with similar specifications!

The new generation jets are huge and require long leads. We recommend to use the S-bus or X-bus system to eliminate interference and power losses in long wires. HV servos are best for the hawk.

The trend nowadays is to use dual battery management systems and dual RX equipment. With the introduction of 2.4 Ghz even quad RX systems are considered as normal for a jet model.

Always center and install the correct output arms while on the bench, once the servo is in the aircraft access to the servo arm screw is sometimes limited. The JR Matchbox makes this task very easy. Some power boxes also include this servo matching function.

Do not save any money when buying radio equipment. The price of servo's are far from the price of replacing the entire model.

REMEMBER: The best equipment is only as good as the weakest link. Ask yourself if this servo or link or lead etc is worthy of my trust to protect my very large investment...

Accessories

The full size Hawk main gear doors are always closed. Accept when retracting. A special air or electronic sequencer is needed for this option.

1. 2 DS8921 HV servo's for the elevator.
2. 1 DS8911 HV for rudder.
3. 2 DS8911 HV servo's for ailerons
4. 2 DS8911 HV servo's for flaps
5. 1 JR8911 HV steering servo.
6. 3 Standard JR577servos for Landing Gear, Door and Wheel Brake valves or check next line.
7. 2 2way jettronic and 1 1way jettronic valve and sequencer for landing gear + doors + brakes
8. 1 2way jettronic valve for speed brake
9. 1 2way jettronic valve for canopy lock
10. 1 Powerbox Royal with build in matchbox function and HV servo output.
11. Pneumatic support set for landing gear (air tubing, valves, Tee's, fill valves, air tanks etc.)
12. Turbine motor, with thrust range between 20kg, with ECU, fuel pump, battery and solenoid valves, mounting strap etc. One of the common choices is the K200G kingtech.
13. Fuel tubing, Hopper tank (or BVM UAT), festo fittings, fuel filters, fuel tube clamps etc.
14. Cable ties in various lengths. Cable management parts, Aluminum tape, safety clips etc.
15. Optional 2 servos (5kg) for locking main gear doors.
16. Optional light kit

***Did you understand everything in this manual completely?
Then, and only then, let's start assembling your Hawk..
If not, please read it again before you start the assembly.***

Hawk arf pro

Kit Contents

Assembly & Operation Manual



Rear & Centre Fus & Hatches



Nose Section with LG



Wings with LG



Fin & Rudder



Elevator



Canopy and Frame



Flaps

Hawk arf pro

Assembly & Operation Manual

Hardware



Photo 1



Photo 2



Photo 3



Photo 4

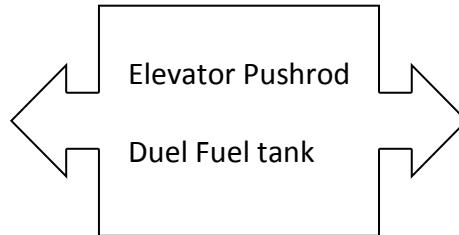

Photo 5

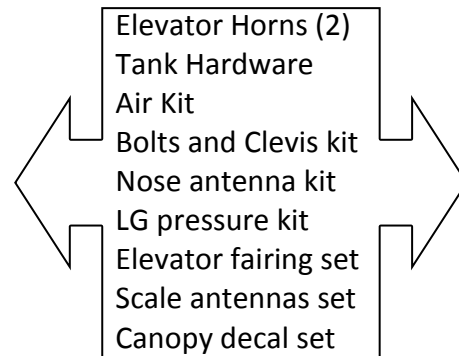

Photo 6

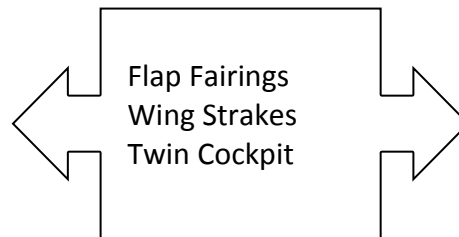

Photo 7

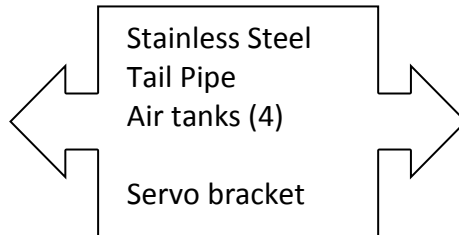

Photo 8



Hawk arf pro

Assembly & Operation Manual



Photo 9

OPTIONAL PARTS

Hawk T1 Light kit
Hawk100 Light kit



Photo 10



Photo 11

Hawk T1 Belly Tank
Hawk 100 Ordnance



Photo 12



Photo 13

Hawk T1 Antenna
Hawk100 Antenna



Photo 14



Photo 15

Air Disconnects
Bypass Carbon



Photo 16



Photo 17

Hawk 100 Pylons
Hawk wing bag



Photo 18

Skymaster
ARF PLUS

Hawk arf pro

Assembly & Operation Manual

WINGS

NOTE: Make sure to have some sort of protective foam on the work bench. This will protect the paint surface from unwanted dents. Assemble both wings simultaneously. Mark ✓ each step.

- Check operation of Landing gear and doors.
- Inspect landing gear blocks. Make sure all parts are glued.
- Fit quick disconnects to air line.
- Tighten all screws on wheels.
- Check the operation of brake
- Remove and mark servo covers and inspect plywood. Use dremel to clean out some glue and ply to make sure servos will fit well.
- Fit L-shape servo brackets to JR DS8911

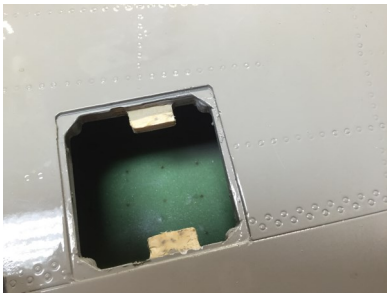

Photo 19

- Aileron servo must be mounted with horns facing up and must be closest from control surface
- Secure servo horn and center servo with TX.
- Secure extension wire. Use safety clips on joint.
- Fit servo to wing.
- Draw a line perpendicular to hinge line.



Photo 20

- Mark off area for aileron horn. Use dremel tool to cut slot.
- Glue horn in place.
- Fit pushrod. Mark location for fearing and secure in position.



Hawk arf pro

Assembly & Operation Manual



Photo 21



Photo 22

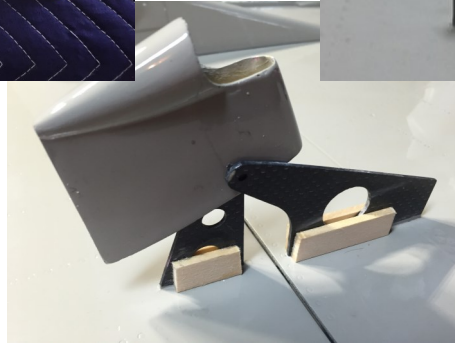

Photo 23

- All carbon flap hinges are factory installed.
- Check that slots for flap hinges line up. Pivot point must be where leading and trailing edge meet.
- Check operation of flap.
- Slide fairings over hinges. Mark location of scrap plywood and glue the 3/32" plywood to hinge. This will form structure to mount the fairing. Note large fairing is center fairing.
- When happy screw the fairings in position. Check operation of flaps.



Photo 24

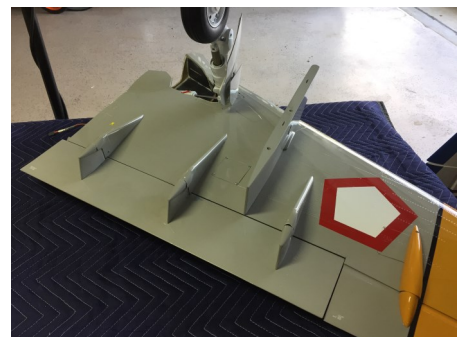

Photo 25

Skymaster
ARF PLUS

Hawk arf pro

Assembly & Operation Manual

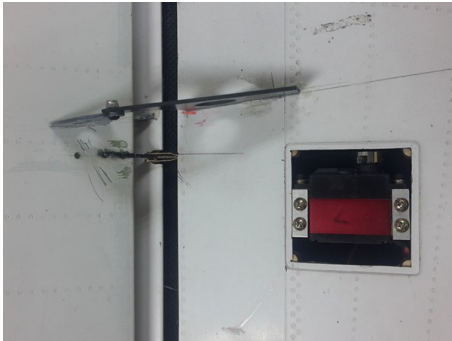

Photo 26

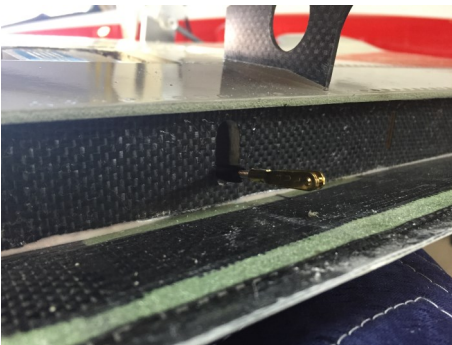

Photo 27

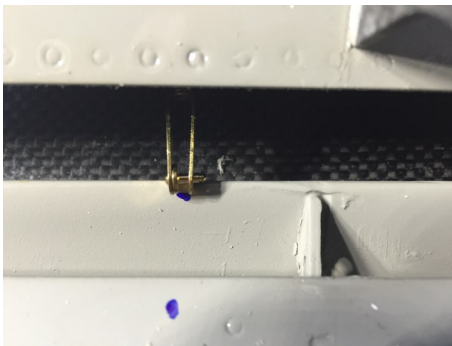

Photo 28

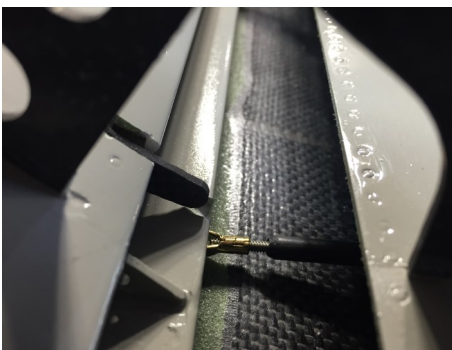

Photo 29

- Fit 2 x L-brackets to 8711 servos.
- Secure servo horn to servo and set travel with TX.
- Fit servo to ply mount with horn facing down.
- Draw line perpendicular to hinge line and mark location of flap pushrod.
- Cut hole in trailing edge of wing and feed pushrod through hole.
- Secure pushrod to servo horn.
- Mark location for flap horn on leading edge of flap. (Note: Make sure flap can travel at least 45 degrees down and fully up.)
- Mark location for horn and cut slot in flap.
- Glue horn in position. When cured check operation of flap.
- Feed servo wires through ribs until it reaches the root rib.
- Cut hole for servo wires and secure with cable ties.
- Repeat page 12—14 for other wing.
- Fit servo covers.
- Trial fit wings to fuselage and mark location of hole for servo wires.
- Cut hole in fuselage for servo wires.
- This complete this section.

Hawk arf pro

Assembly & Operation Manual

STABILIZER

NOTE: Make sure to have some sort of protective foam on the work bench. This will protect the paint surface from unwanted dents. Mark ✓ each step.

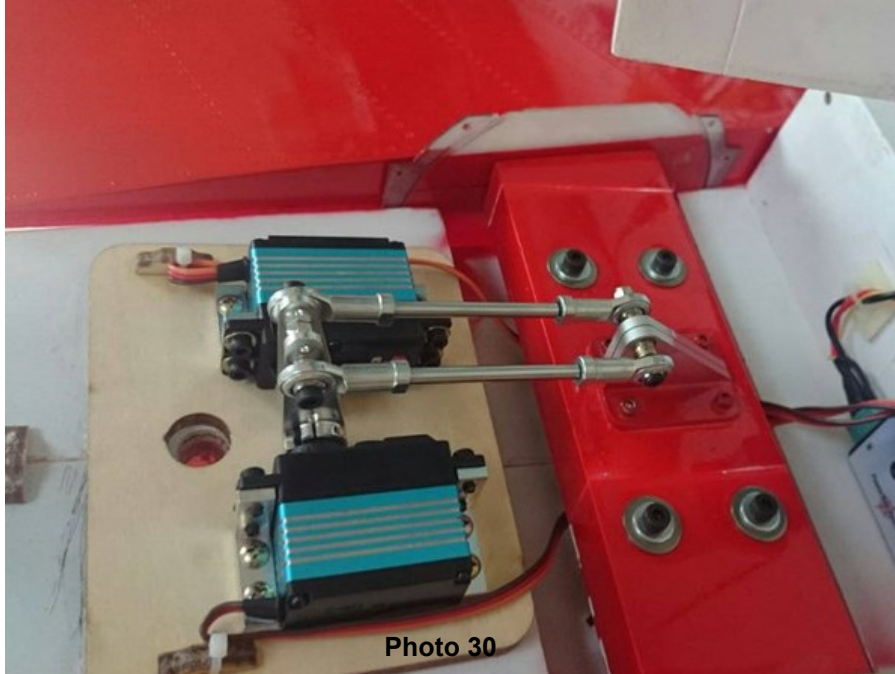

- Fit 4 x L-brackets to 2 x 8911HV servos. Servo's mirror image of each other.
- Fit servo horns and adjust travel and sub-trim with TX.
- Check that all bolts of elevator bearing blocks are tight. Use lock nuts and loctide if needed.
- Bolt elevator horn to elevator. Use lock nuts.
- Bolt elevator to bearing blocks mounted to fuselage. Use lock nuts.
- Make up to identical elevator pushrods. Use bearing mount pushrods.
- Fit pushrods to servo horns and elevator horn.
- Use AMP—meter to setup neutral position and travel. Make sure servo's do not fight each other.
- Fit sliding discs over elevator brace.
- Slide the servo cover in position and guide discs between sliders. When happy secure cover and sliders with 2mm screws.

Hawk arf pro

Assembly & Operation Manual

- Check operation of elevator.
- Make sure no slop and binding in system
- Run servo wires together in harness.

NOTE : Make sure no wires can touch tailpipe. Touching tailpipe will melt wires and create short circuit. This will lead to crash.

FIN & RUDDER

NOTE: Make sure to have some sort of protective foam on the work bench. This will protect the paint surface from unwanted dents. Mark ✓ each step.



Photo 31

- Slide bellcrank shaft through tube.
- Fit the horns to the shaft of bellcrank.
- Fit servo to plate. Centre servo horn.
- Fit push pull pushrods to bellcrank.
- Make sure no slop in system.



Photo 32

Skymaster
ARF PLUS

Hawk arf pro

Assembly & Operation Manual



Photo 33



Photo 34

- Trial fit fin to fuselage.
- Rudder is pinned hinge to fin. Fit rudder to fin.
- Fit fin and rudder to fuselage.
- Clamp fin to fuselage.
- Check movement of rudder—check for any slop. Slop will cause flutter and will brake fin.
- This complete this section.



Hawk arf pro

Assembly & Operation Manual

FUSELAGE

Make sure you have a good stand for fuselage. You will need to assemble the rest of the Hawk on this stand. The fuselage is in 3 sections. We have made removable rear section for ease of transport to and from flying field. We suggest to use quick connectors for air and servo leads to help with easy removable of rear section.



Photo 35



Photo 36



Photo 37

- Locate the 6 x M5 bolts and washers for fuselage.
- Align fuselage and secure with 6 bolts.
- Turn fuselage and remove the nose retract unit.
- Install horn & ball to JR DS8911 steering servo and center servo.
- Refit nose retract unit with good quality screws.



Photo 38



Photo 39



Photo 40



Photo 41

- Locate rear fuselage and check the alignment. Secure temporarily.
- Route servo wires and air lines from speed brake neatly along inner skin of rear fuselage to nose.
- Make sure no air line & servo wires can come in contact with hot parts of turbine and pipe.
- Operate nose unit and doors and check operation. Close the door and check clearance all around wheel.
- For Hawk 100 additional fins are located in front of elevator. Mask off area and glue fins in position. Install the rear bottom fins.

Hawk arf pro

Assembly & Operation Manual

TAIL PIPE

- Drill holes in mounting lugs of tail pipe.
- Trial fit bypass to tail pipe.
- Slide tail pipe through hatch into position. Note: The rear of pipe must just be level with rear of fuselage
- Mark location of screws on turbine rail.
- Drill pilot holes for self tap screws.
- Secure pipe in position and glue end of pipe with silicon glue to former.
- Glue bell mouth with silicon glue.



Photo 36



Photo 37

FUEL CELL

- Rinse the fuel tank and check for leaks.
- Make up fuel line clunk. Make sure clunk moves freely and reaches all corners of inside of tank.
- Fit to tank. Mark pipes for “inlet” and “outlet”.
- Install tank by making up scrap plywood mounts.
- Plumb tanks using diagram on next page.
- Fill tanks and check for leaks.
- Drain tanks with fuel pump and check no air bubbles in system until last drop is drained. A good plumbing will secure good turbine operation.

Optional smoke tank shown. (smaller tank)

NOTE: It is very important to mount the tanks at correct location. Changing the location will make jet unstable!



Photo 42

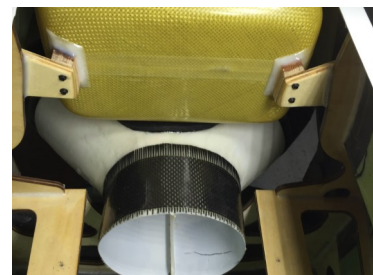

Photo 43



Hawk arf pro

Assembly & Operation Manual

FUEL
GRAM

CELL DIA-

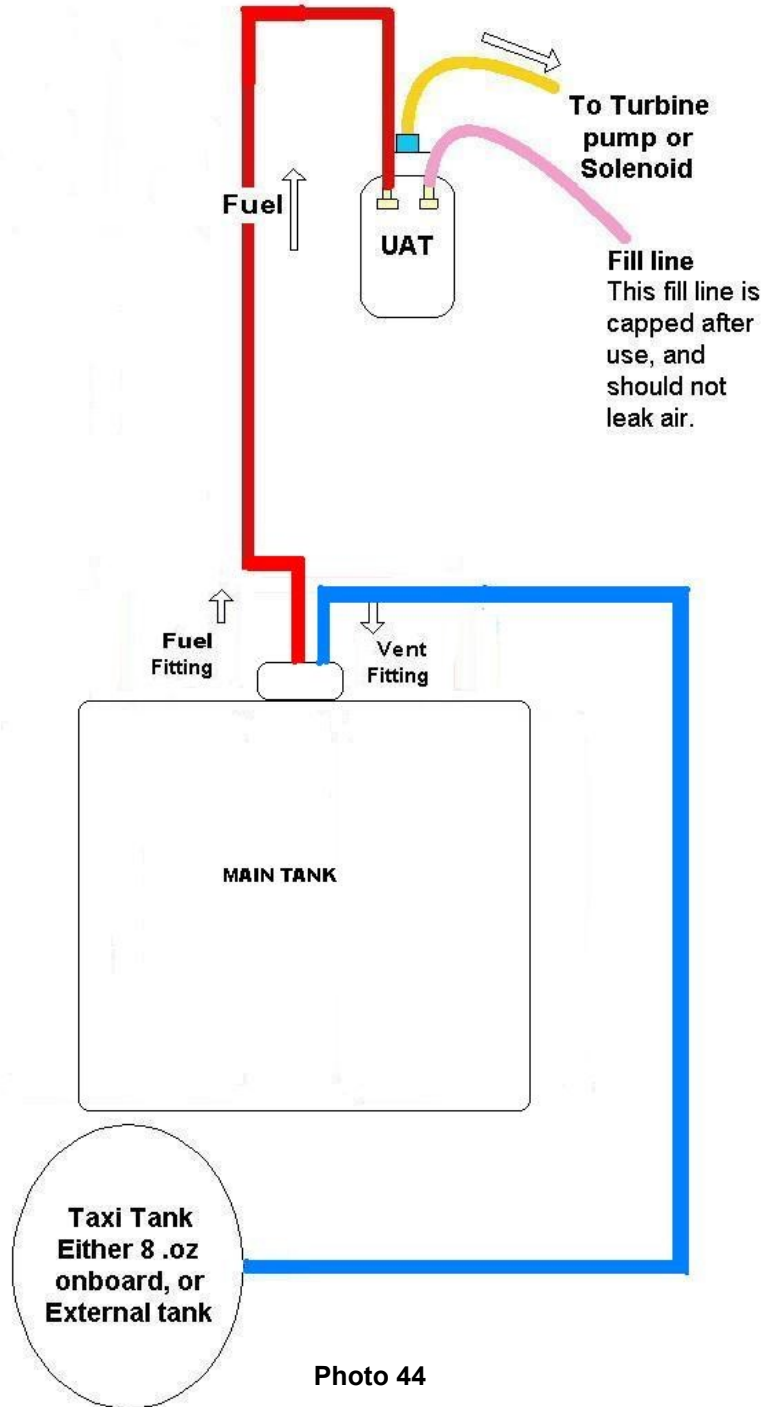

Photo 44

Skymaster
ARF PLUS

Hawk arf pro

Assembly & Operation Manual

AIR SYSTEM There are a couple of options available to builder. We at Skymaster still believe that our retracts are the best of the best and have chosen air driven system, Therefore we will describe air system. If you chose to use servo and electronic retracts, follow the instructions of supplier.

The plumbing required is for the retracts , doors, brakes, speed brake and canopy lock.

- You can use air tank for each of the systems or share tanks, I suggest you use a large air tank for retracts and do not share this tank. Glue these air tanks on the floor of the fuselage with silicon. Use best location for your setup.
- You will need 4 x 2way valves and 1 x 1 way valve with sequencers. We use the Jettronic valves and sequencers. Some powerbox include sequencers.
- Fit the 3 filler valves and 3 pressure gauges onto accessory tray.
- Plumb the landing gear, door and brake system by using color coded air tubing. T all same color tubing together until a single pipe emerge. Use quick disconnects in wing.
- Plumb speed brake. Use disconnects where fus joins
- Plumb the canopy locks and secure to valve. Could be assigned to switch on tx.
- Air leaks can damage your model! Please do a thorough check for air leaks. Make sure the system can hold pressure for at least an hour in the up and down position.
- Do not rush this installation.



Photo 45



Photo 46



Photo 46



Photo 47

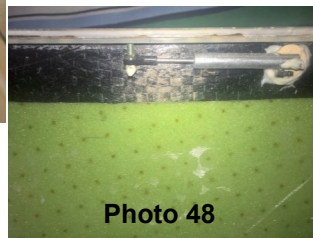

Photo 48



Photo 49



Hawk arf pro

Assembly & Operation Manual

- For scale functions on L/G you will require additional 2 way electronic valves. The main doors in the fuselage will stay close before and after retraction. This can easily be programmed together with powerbox royal

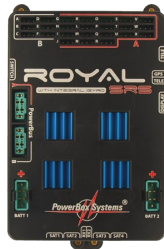

Photo 50 PB Royal

AIR DIAGRAM

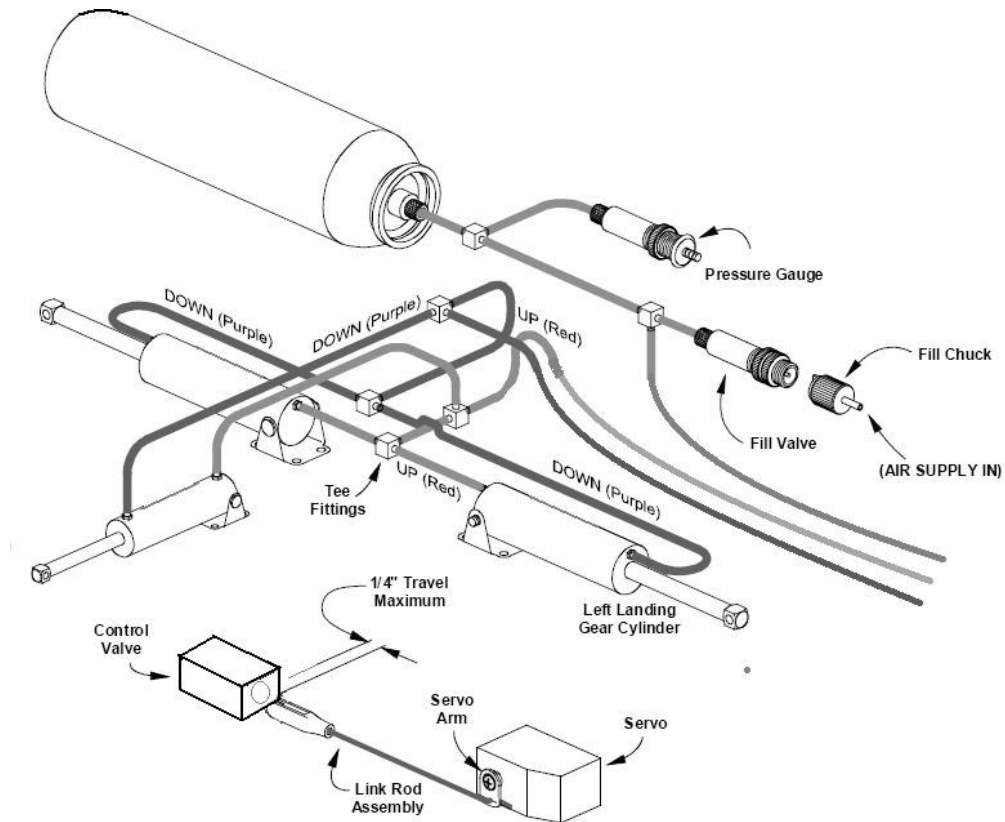
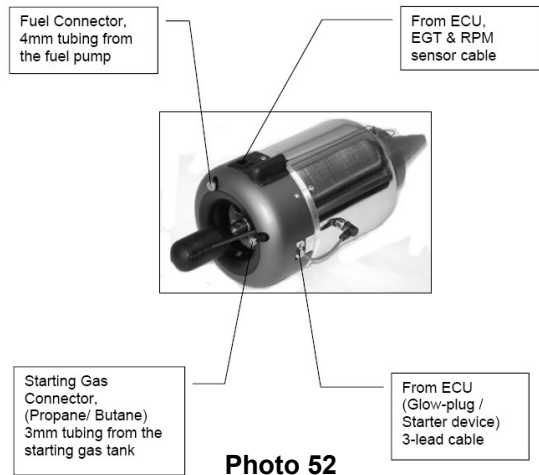

Photo 51 Diagram for retracts



Hawk arf pro

Assembly & Operation Manual



TURBINE INSTALLATION

- Please follow the instructions supplied with your turbine.
- Secure turbine to turbine rail via hatch at bottom of fuselage. Leave gap of 25mm between NGV and tailpipe.
- Run all turbine wires and power cables on opposite side of servo wires.
- Always secure all wires in harness. I would suggest you install a FOD. This will save you money in the long run.

- Install fuel pump close to UAT. We recommend to make use of a mechanical shut off valve as well.
- Secure all Festo pipes with cable ties. Make sure fuel filter and gas canister are mounted vertical.
- Install Li Po battery in nose. I always put a fuse holder inline with power cable.
- A bypass always looks good and improve the aerodynamics of model.

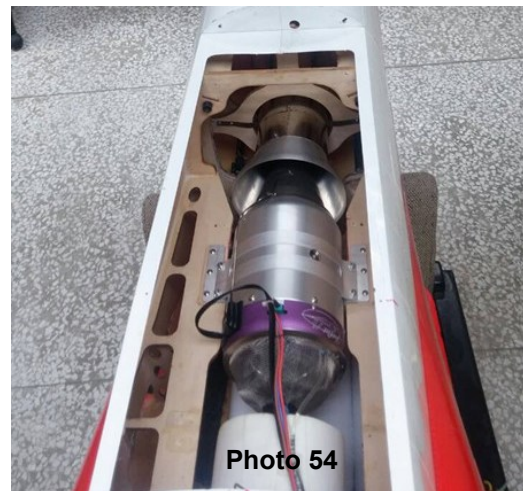
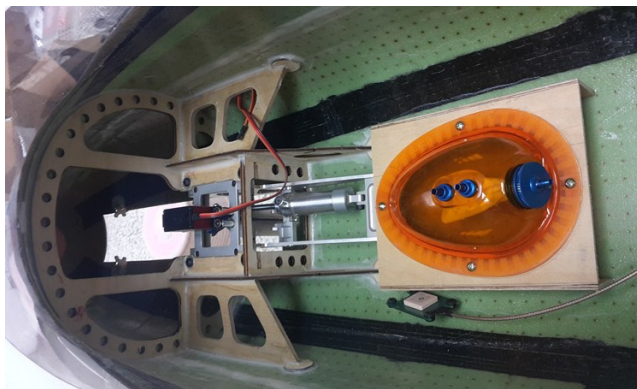

Skymaster
ARF PLUS

Hawk arf pro

Assembly & Operation Manual

COCKPIT AND CANOPY (after painting)

- Trace the shape of canopy and cut to fit. Glue with canopy glue. (only for white ordered model)
- Trial fit cockpit and cut to fit.
- Glue cockpit to canopy frame.
- Canopy on Hawk is side hinges just like full size.
- It requires a canopy lock system to be installed. This was done via factory if this option was ordered.
- White self adhesive decals are supplied with white airframe. This decal must be installed inside canopy.



Photo 55



Photo 56

Skymaster
ARF PLUS

Hawk arf pro

Assembly & Operation Manual

EQUIPMENT INSTALLATION INTO HAWK

□ Equipment installation is a personal venture. There is one golden rule: Do it as neat and logical as possible! This will make fault finding and service of components easier. The Hawk basically consist of 6 circuits!

1. Servo wires / Bus
2. Power cables
3. Data cables
4. Pneumatic pipes
5. Fuel pipes
6. RX cable / Satellite Receivers

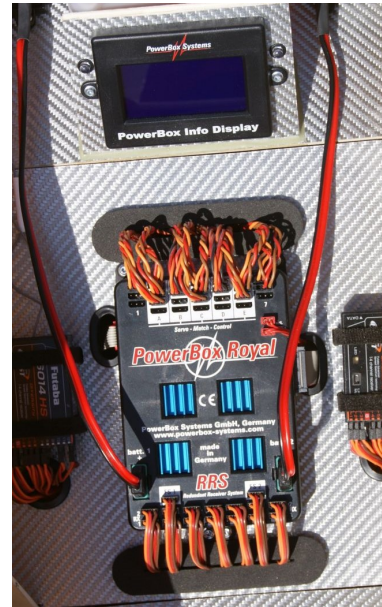

Photo 58

Please try and separate these circuits as far as possible. It is advisable not to run RX cables near any kind of electrical fields. Make all switches and filler valves and charging sockets easy accessible.

- The Hawk will come out tail heavy if you do not plan installation. It is very important to install all equipment as far forward as possible.
- I have installed 2 x RX + 2 X ECU batteries in front of nose gear. This is weight of 1.2 kg together.
- I have installed a UAT in front of main tank. This will always be full of fuel and will help with the final adjustment of CG.
- The accessory tray must be mounted as low as possible to accommodate cockpit floor.
- Use of powerbox royal or similar with tidy up the installation.



Hawk arf pro

Assembly & Operation Manual

BEFORE YOU FLY

It is assumed that the builder of this kit has acquired the basic skills and knowledge necessary to make a safe and functional radio control installation into a model. Therefore, these notes are intended only to assist that experience.

When inserting the main spar into wing, make sure it only enters the amount required. If you can slide complete main spar into 1 half of wing, it means the stopper were removed. Please measure correct distance for main spar and secure spar so that it does not slide more to one side than other. It must be symmetrical to both sides.

Travel adjust measured at root. Use Expo to suite your style.

1. Elevator	70-75mm	2. Rudder	42mm
3. Aileron	30mm	4. Flaps take off	30mm
5. Flaps landing	70mm		

NOTE : Make sure flaps travel same. Flaps should be deployed in landing circuit only below 90mph.

- CG 315mm—320mm from leading edge at root. Empty tanks, UAT full and wheels down.
WARNING: Do not move CG back unless you are experience and have some feel of model before!
WARNING: DO NOT USE FULL FLAPS WITH HIGH SPEED FLIGHT! THE FLAPS WILL OVER RIDE THE ELEVATOR. WHEN THIS HAPPEN , PUT FLAPS UP AND REDUCE SPEED.
- Weight Dry weight will be between 45 and 55 lbs depending equipment.
- PSI 100—120 psi for pneumatic system
- Power Make use of battery management system. Double up on batteries and make sure all wired can carry current needed to operate.
- TX RX Do a complete range check before flight. Do this with turbine running. Follow manufacturers instructions.
- Speed Set the maximum speed to 180mph! The prototype were tested with Kingtech K210 turbine. More powerful turbines require extra care and extra reinforcing.
- Timer A timer can safe your model. Get into the habit of programming the timer.



Hawk arf pro

Assembly & Operation Manual

Take-Off

Do some taxi tests before your flight! Make sure you are familiar with all settings and make sure the model track straight on the ground without rudder input.

Choose a fine day for the maiden flight. Do not force a maiden flight. Select take off flap or flight mode 1 and open throttle. Gently pull back on stick 30m down the runway. Raise the flaps and gear at safe altitude and feel the hawk.

Slow Flight

Most of the first flight should be utilized to get familiar with the slow speed flight characteristics. Select the flaps to the takeoff position; there should be no pitch change. Extend the gear and select full landing flaps; adjust the power to maintain level flight and a speed of about 80—90mph.

Climb to a safe altitude and slow the model to the edge of a stall to know where that edge is. **NOTE: DEPLOYING OF FLAPS AT HIGH SPEED WILL PUT THE HAWK IN NOSE DOWN ATTITUDE. ELEVATOR CONTROL WILL BE LOST. ONLY DEPLOY FLAPS AT LANDING SPEEDS.**

Landing

Fly a complete circuit before landing. Approach from the downwind side and lower the LG. Fly a complete circuit getting use to the power required. On the next circuit lower the flaps. If you have a headwind be very careful not to get below the power curve on the downwind side. Do not use speed brakes for landing on maiden. When you are happy and more experienced the speed brakes will slow model down faster.

Align the model and use throttle to control the descent! The elevators will stay very active even at low speed. Flare the model just before touch down. Let the model roll out and apply brakes. Nose high landings are easy with a very effective stab.

Taxi back and do necessary adjustments to customize Hawk for your need!

We at Skymaster wish you many happy flights with your Hawk! Add some scale options like drop tanks and landing lights to compliment a very fine model.

Anton Lin and Skymaster Team!



Hawk arf pro

Assembly & Operation Manual

Mechanical Lock on main doors

We have found that in some cases the main doors will open in flight due to high g-forces. We recommend installation of locking servo to keep door locked.

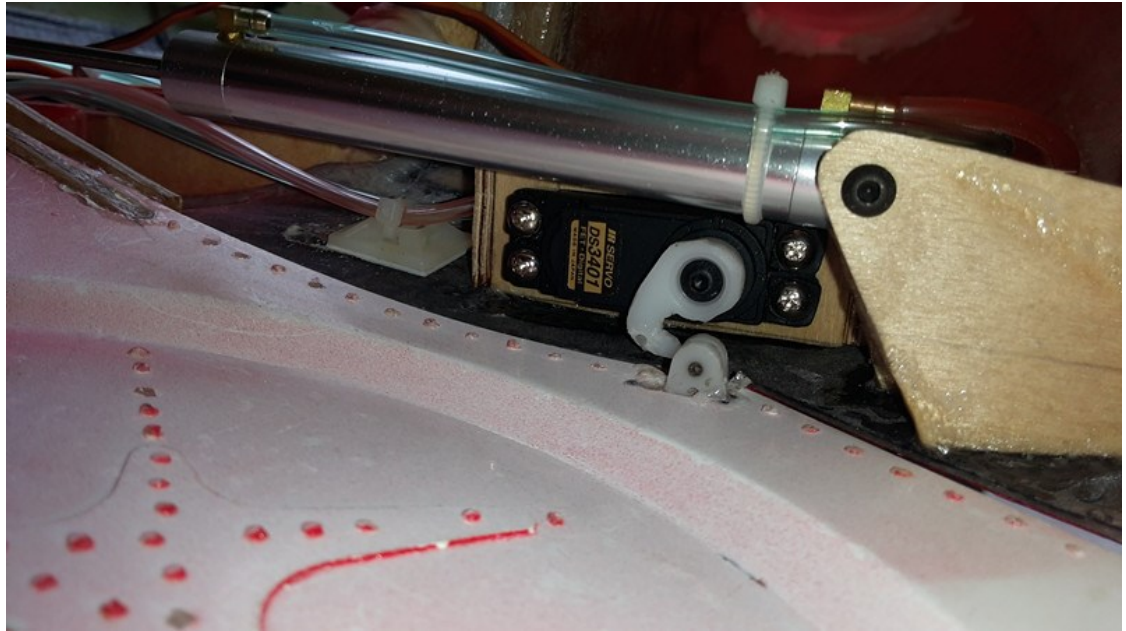

Ordinance

Hawk T1 have belly tank.

Hawk 100 have wing pylons and missile rails.

Optional light kit is available from Skymaster. It could also be factory installed.

